

ROSEWELL HOUSE

CONNECT BUSINESS PARK | EDINBURGH

SUITES FROM 1,300 - 7,784 SQ FT | BREEAM RATING "VERY GOOD"



PLAY VIDEO

[ROSEWELLHOUSE-EDINBURGH.CO.UK](https://www.rosewellhouse-edinburgh.co.uk)

FIRST CLASS BUSINESS LOCATION.

THE LOCATION

Newbridge is an established commercial business location and the key to its success is excellent connectivity. Connect Business Park provides immediate access to the Scottish motorway network and Central Scotland's cities and towns. The location allows easy access to Edinburgh city centre via car, bus or tram, and Edinburgh Airport is only 2 miles away.

A selection of local amenities are available nearby at Ratho Station, Newbridge, The Gyle Shopping Centre and Hermiston Gait Retail Park.

THE DEVELOPMENT

Connect Business Park is an impressive development situated in Newbridge. Rosewell House provides a striking Grade A building which fulfils modern occupier needs.

The available suite on the first floor offers high quality office accommodation with a specification including raised access flooring, suspended ceiling with LG7 lighting and VRF heating and cooling system.

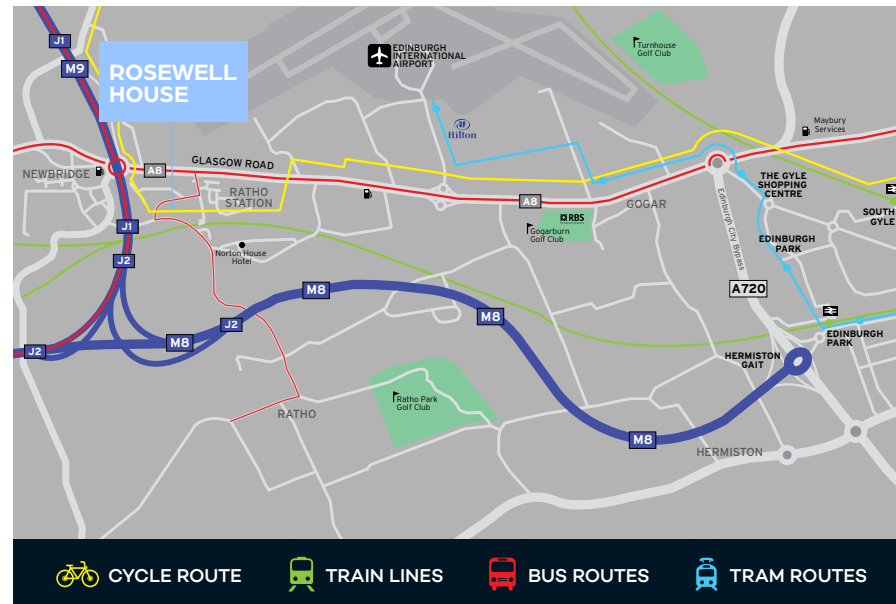

2 MINUTES
From M8/M9 Interchange

City centre: 22 mins
Livingston: 10 mins
Glasgow: 43 mins



30 MINUTES
By bus to the City centre

Lothian, First, Citylink and Stagecoach operate 12 services



7 MINUTES
Edinburgh International Airport

London: 1 hr 15 mins
Manchester: 1 hr
Dublin: 40 mins



10 MINUTES
Edinburgh Park and Ride and South Gyle Train Station

City centre: 6-10 mins

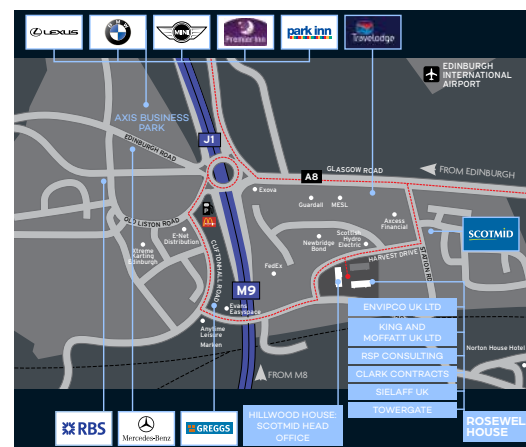



GRADE A SPECIFICATION OFFICES.

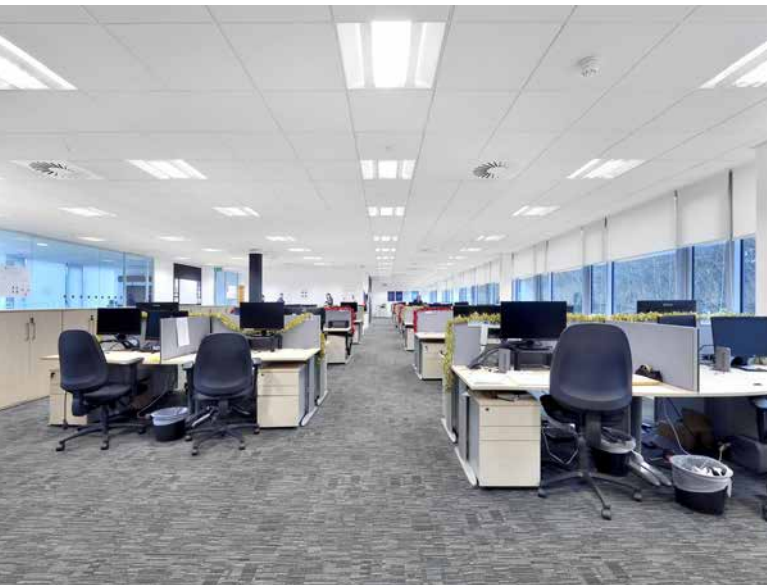

SPECIFICATION

Extensive car parking and EV charging points

Energy efficient VRF heating and cooling system

2 passenger lifts

Male, female and fully accessible toilets on each floor

Shower facilities

Raised access floor

Floor loading 4+1 KN/m²

Floor to ceiling height 2.7m

Suspended ceiling with energy efficient LG7 lighting

BREEAM "Very Good"

EPC rating 'A'

AVAILABLE ACCOMMODATION

The available accommodation has been measured in accordance with the RICS Code of Measuring Practice (Sixth Edition) and extends to the approximate Net Internal Areas detailed below:

| FLOOR | SIZE (sq m) | SIZE (sq ft) |
|---------------|---------------|--------------|
| Ground | 120.77 | 1,300 |
| 1st (Suite 1) | 124.50 | 1,340 |
| 1st (Suite 2) | 177.10 | 1,906 |
| 1st (Suite 3) | 300.80 | 3,238 |
| TOTAL | 723.17 | 7,784 |



GROUND FLOOR

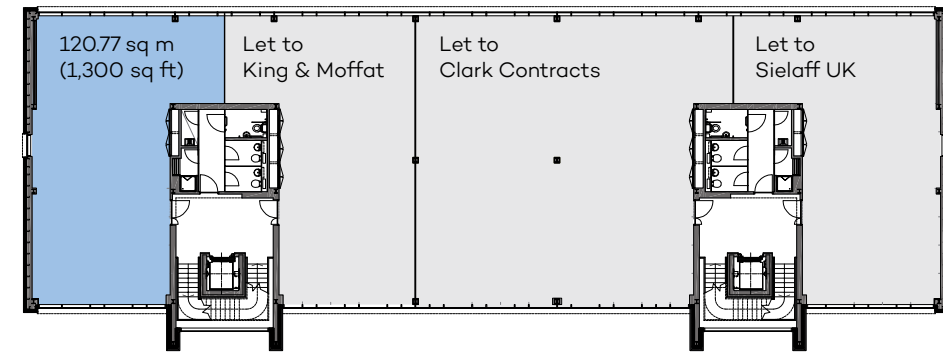

FIRST FLOOR

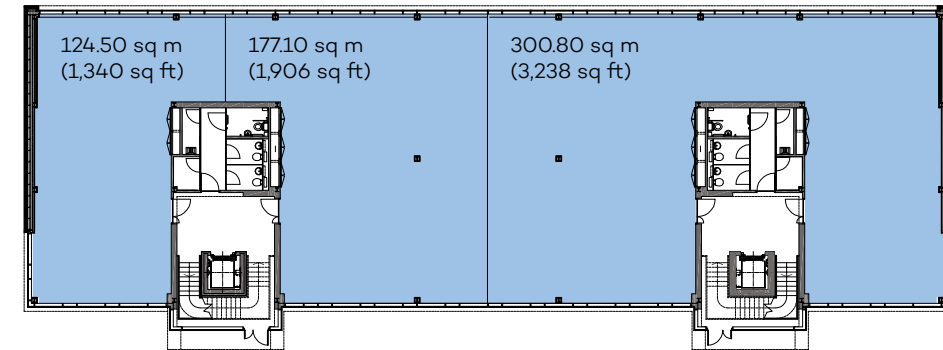

SECOND FLOOR

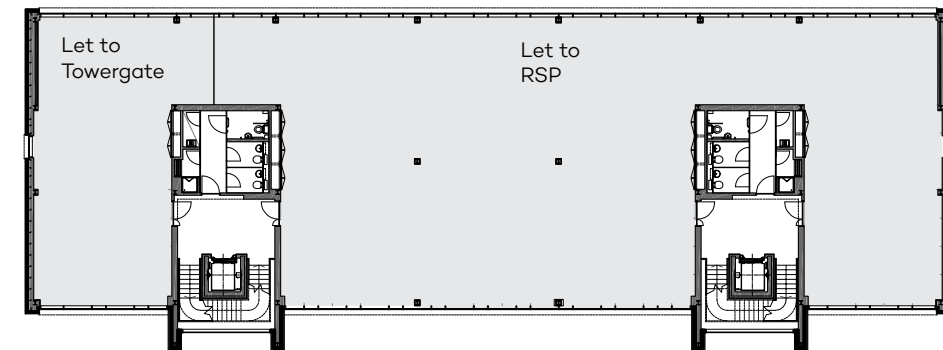

TERMS

The accommodation is available on full repairing and insuring terms. Rental information is available upon request.

VAT

This property is elected for VAT.

LEGAL COSTS

Each party will be responsible for their own legal costs with the in-going tenant being liable for land and building transaction tax (LBTT) and registration dues.

EPC

The property has an Energy Performance Certificate rating of "A". A copy of certificate is available upon request.

BREEAM RATING

This property benefits from a BREEAM rating of 'Very Good'.

RATING

The incoming occupier will be responsible for the payment of Local Authority Rates.

It is recommended that interested parties contact Lothian Valuation Joint Board directly for rating information (0131 344 2500).

FURTHER INFORMATION

By contacting joint letting agents Ryden and Cushman & Wakefield.



E: stewart.mcmillan@cushwake.com
T: 07887 795 503

Ryden.co.uk

E: iain.taylor@ryden.co.uk
T: 07884 322 759

E: kyle.wright@ryden.co.uk
T: 07425 478 303

The Agents for themselves and for the vendors or lessors of this property whose agents they are give notice that: (i) the particulars are set out as a general outline only for the guidance of the intended purchasers or lessees and do not constitute, nor constitute part of, an offer or contract; (ii) all descriptions, dimensions, reference to condition and necessary permissions for use and occupation, and other details are given without responsibility and any intending purchasers or tenants should not rely on them as statements or representations of fact but must satisfy themselves by inspection or otherwise as to the correctness of each of them; (iii) no person in the employment of the Agents has any authority to make or give any representations or warranty whatever in relation to this property.
February 2025. **Produced by Designworks**